

McHenry

PRESSURE CLEANING SYSTEMS

301-663-4683 or 800-221-6905

SALES • SERVICE • RENTALS

www.mchenrypcs.com

Water Treatment Systems

WOS Series

WCL Series



For effective settling and easy handling of solids, choose from our WOS Series with above-ground oil, water and solids separators, three-stage stainless steel tanks, and bio-film generative media or our WCL Series with cone-shaped clarifier tanks and solid separation chambers. Both are designed to remove free oils before discharging equipment and vehicle wash-water into sanitary sewers. These water treatment systems feature a surface-mount sump pump, corona discharge ozone injection and oil skimmer.

Perfect for heavy equipment dealers, trucking facilities, forklift washing operations, aircraft maintenance and restoration and oil fields, the WOS Series and WCL Series Water Treatment Systems are capable of handling oil and solids conveniently and effectively with easy maintenance.

Above Ground Oil/Water/Solids Separator

We have oil/water separator systems to remove free oils before discharging to your sanitary sewer. The oil/water/solids separators will reduce the amount of suspended solids while removing hydrocarbons to meet stringent local sanitary sewer discharge requirements.

The WOS Series consists of above-ground oil/water/solids separators designed to discharge equipment and vehicle wash-water to sanitary sewers.

The WOS Series offers the following features:

- Capability of handling oil and solids conveniently
- Takes up an extremely small footprint
- Easy to maintain
- CSA approved control panel which meets the requirements of the US and Canadian standards for an Industrial Control Panel
- 1.0 HP surface-mount sump pump included



CSA listed NEMA-4 rated corrosion-proof control panel for safe and reliable operation

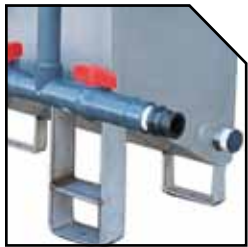

Tank is sloped for easy drainage



WOS-15-OM10

Model Number	Flow Rate	Coalescing Media	Tank Holding Capacity	In-line Strainer Pump	Power Requirements	Dimensions (LxWxH)	Ship Wt.
WOS-15-OM10	0-15 GPM	672 sq. ft.	170 gallons	1.0 HP, 120V	120V, 1Ø, 15.0A	91 in. x 31 in. x 40 in.	675 lbs.
WOS-15-OM30	0-15 GPM	672 sq. ft.	170 gallons	1.0 HP, 120V	208-230V, 3Ø, 5.0A	91 in. x 31 in. x 40 in.	675 lbs.
WOS-30-OM10	0-30 GPM	1,152 sq. ft.	340 gallons	1.0 HP, 120V	120V, 1Ø, 15.0A	97 in. x 50 in. x 44 in.	865 lbs.
WOS-30-OM30	0-30 GPM	1,152 sq. ft.	340 gallons	1.0 HP, 120V	208-230V, 3Ø, 5.0A	97 in. x 50 in. x 44 in.	865 lbs.

OPTION

Part Number	Description	Fits Models
WX-0001	Continuous recirculation option - recirculates water back to the pit	All models

WOS Process & Flow Description

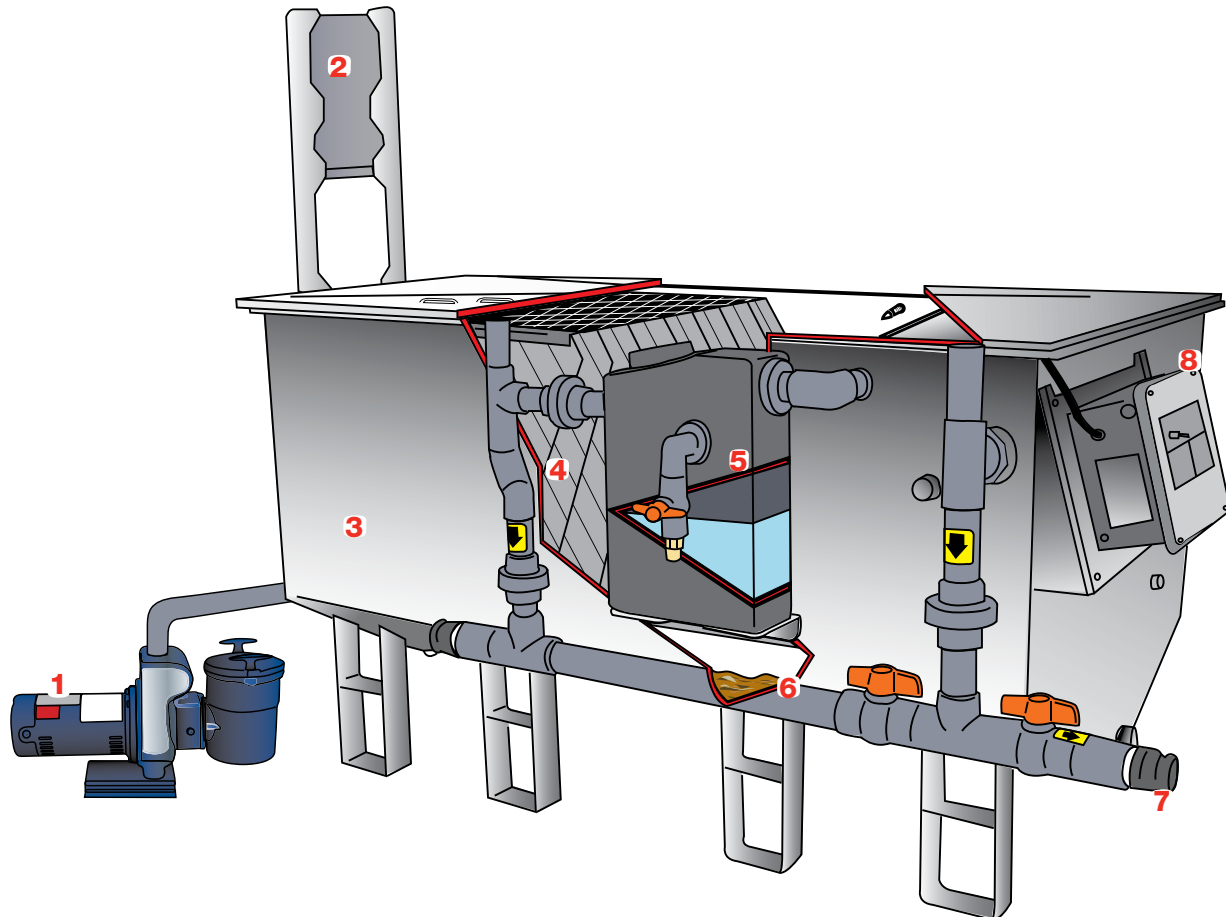

- 1. Surface-Mount Sump Pump** – Untreated wash-water is introduced into the system via a 1.0 HP surface-mount sump pump, which is included in the unit.
- 2. Corona Discharge Ozone System** – As the wash-water is pumped into the oil/water/solids separator, it is injected with a high concentration of ozone via a corona discharge ozone injector system for a "quick kill" of live bacteria on contact.
- 3. Three-Stage Stainless-Steel Tank** – As the water flows through the stainless-steel three-stage oil/water/solids separator, it changes the overall flow direction several times as it flows around four vertical baffles. The water is slowed down and fine silt and solids drop to the bottom of the tank.
- 4. Bio-Film Generative Media** – As the water progresses through hundreds of square-feet of honey-combed-shaped meshed oleophilic (oil attracting) coalescing media, it will change directions countless times. In this process, mechanically emulsified oil particles are attracted from the water to the oleophilic media, and float to the surface.
- 5. Oil Skimmer/Decanter** – Once the oil floats to the water's surface, it is then skimmed into an oil decanter for easy disposal.
- 6. Sloped Solids Trap** – Fine silt and particles are dropped to the bottom of the sloped stainless-steel tank for easy flushing and disposal of the accumulated solids.
- 7. Discharge Port** – Once the water has been treated, it flows into the final chamber of the stainless-steel tank and is gravity-fed through a 2-inch drain line to the sanitary sewer drain in the floor.
- 8. Electrical Control Box** – CSA listed NEMA-4 rated corrosion-proof control panel for safe and reliable operation.

WOS Sample Equipment Wash Pad Application

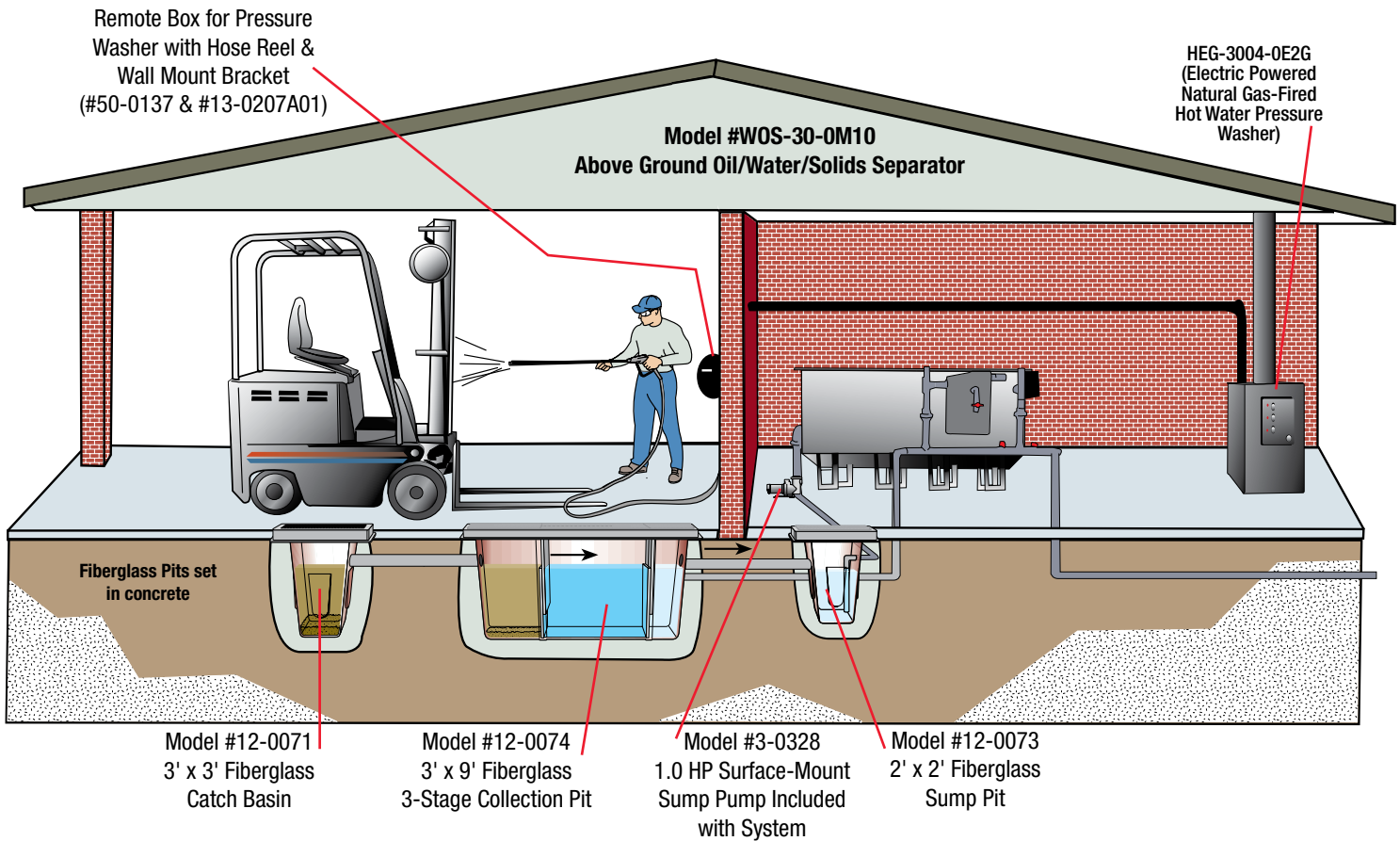

The WOS Series is perfect for the following applications:

- Rental Yards
- Heavy Equipment Dealers
- Trucking Facilities
- Military Bases
- Truck Rental Fleets
- Diesel Repair Facilities
- Forklift Washing Operations
- Aircraft Maintenance & Restoration
- Shipyards
- Municipalities/State DOTs
- Oil Fields
- Engine Rebuilders & Manufacturers

The Importance of a Proper Pit System

Once equipment is washed, the untreated wash-water flows into your pit system. A proper pit system for your application is the first step in proper wash-water treatment, and a critical element in any wash-water recycle system.

Consult McHenry Pressure Cleaning Systems to determine the pit system configuration that works best with your application.

WCL Clarifier & Oil/Water Separator

This mechanical oil/water separator system removes free oils before discharging to your sanitary sewer. The oil/water/solids separators will reduce the amount of suspended solids while removing hydrocarbons to meet stringent local sanitary sewer discharge requirements.

The WCL Series models feature:

- A choice between a 600-gallon or 300-gallon cone-shaped tank for effective settling and easy handling of heavy solids
- A 1.0 HP surface-mount sump pump
- Solids separation chamber with bag filter and decanting
- Oil skimmer and decanter for easy handling of oil
- CSA approved control panel which meets the requirements of the US and Canadian standards for an Industrial Control Panel



A conveniently located, CSA listed NEMA-4 rated, control panel makes equipment simple to operate and is easily accessible (WCL-30D-0M10 only)



Ozone generator for a "quick kill" of live bacteria on contact (WCL-30D-0M10 only)



855-0016



WCL-30D-0M10 shown with optional mezzanine stand (#RC-0005-0001) and 165-gallon storage tank (#855-0016)

Model Number	Flow Rate	Clarifier Tank	Oil Coalescing Area	Power Requirements	Dimensions (LxWxH)	Ship Wt.
WCL-10S-0M10*	0-10 GPM	300 gallons	48 sq. ft.	230V, 1Ø, 8.0A	48 in. x 86 in. x 115 in.	641 lbs.
WCL-30S-0M10*	0-30 GPM	600 gallons	73 sq. ft.	230V, 1Ø, 8.0A	63 in. x 102 in. x 115 in.	725 lbs.
WCL-30D-0M10	0-30 GPM	600 gallons	425 sq. ft.	230V, 1Ø, 13.0A	63 in. x 102 in. x 115 in.	980 lbs.

*Float consists of 230V plug.

Surface-mount sump pump included on all models.

ACCESSORIES

Part Number	Description	Fits Models
855-0015	80-gallon, treated-water storage tank	All models
855-0016	165-gallon, treated-water storage tank	All models
RC-0005-0001	Mezzanine stand	WCL-30 models

WCL Process & Flow Description



- 1. Clarifier Tank** – A 300-gallon or 600-gallon cone-shaped clarifier settles solids. Free-floating oils are removed via a suspended oil skimmer. Model WCL-30D-OM10 has 425 sq. ft. of oil coalescing media to help capture mechanically emulsified oil.
- 2. Control Panel** – This CSA listed NEMA-4 rated control box makes the equipment simple to operate and is easily accessible. (Standard on WCL-30D-OM10)
- 3. Corona Discharge Ozone Injection** – For odor control, the WCL-30D-OM10 comes with a corona discharge ozone generator. The ozone generator has an output of 0.5 grams per hour of ozone for "quick kill" of live bacteria on contact.
- 4. Treated-Water Holding Tank (Accessory #855-0015 or #855-0016, available in 80 and 165-gallon capacity)** – Treated-water holding tank for transferring treated water to the next process or point of discharge.
- 5. Solids Separation Chamber** – Solids from the wastewater stream settle at the base of the clarifier tank. With the opening of a single valve, solids are easily dropped into a bag filter in the solids separation chamber for effective capture and easy disposal. The bag filter is suspended on a de-watering tray with drainage returning to the in-ground collection pits.
- 6. Surface-Mount Sump Pump** – Untreated wash-water is introduced into the system via a 1.0 HP surface-mount sump pump, which is included with the unit.
- 7. Oil Decanter** – Oil skimmed from the surface of the clarifier tank is captured in a conveniently located oil decanter. Oil can be removed easily for appropriate disposal.
- 8. Mezzanine Stand (Accessory #RC-0005-0001)** – A maintenance ladder and platform is available for the WCL-30 series for convenient access to the oil skimmer and to the top portion of the tank.

WCL Sample Equipment Wash Pad Application

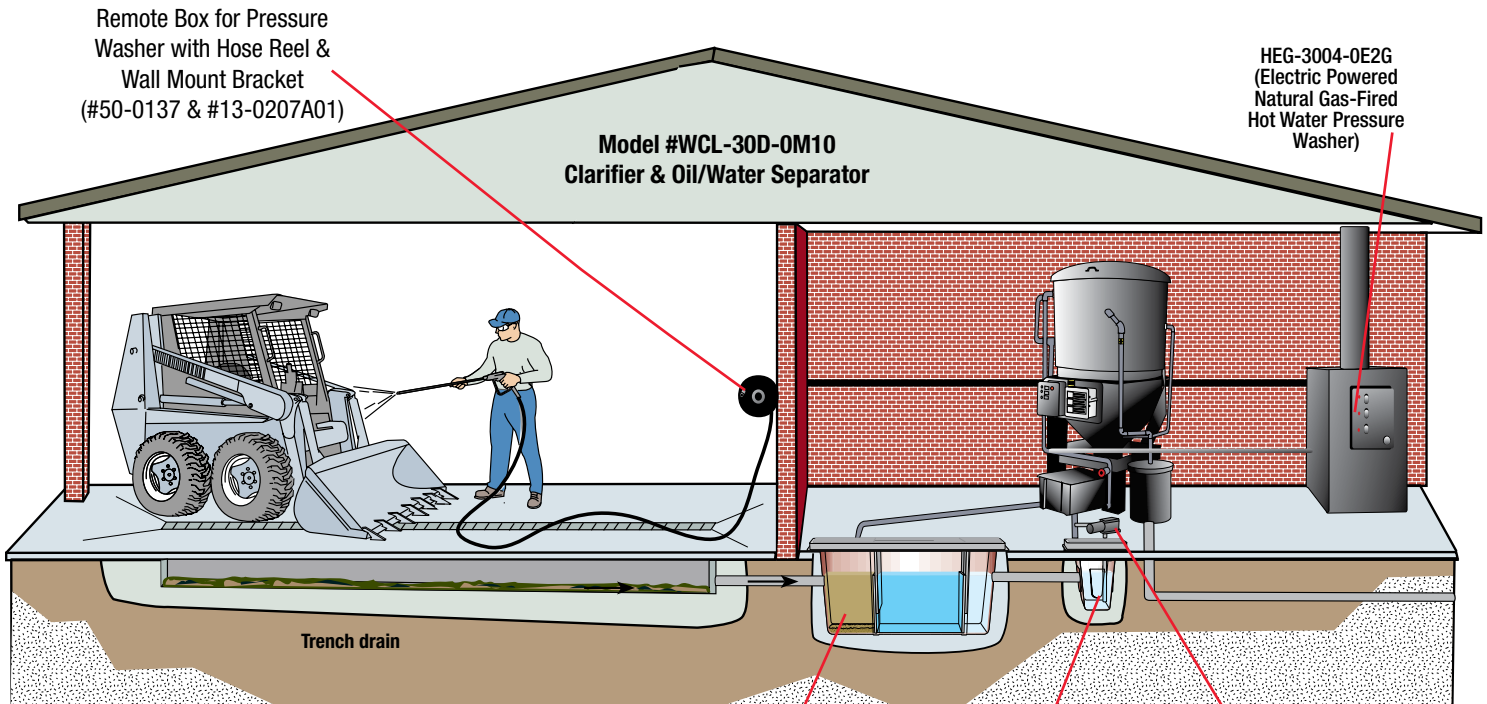

The WCL Series is perfect for the following applications:

- Rental Yards
- Golf Courses
- Heavy Equipment Dealers
- Trucking Facilities
- Military Bases
- Truck Rental Fleets
- Diesel Repair Facilities
- Forklift Washing Operations
- Aircraft Maintenance & Restoration
- Shipyards
- Municipalities/State DOTs
- Oil Fields
- Engine Rebuilders & Manufacturers

Model #12-0074
3' x 9' Fiberglass
3-Stage Collection Pit

Model #12-0073
2' x 2' Fiberglass
Sump Pit

Model #3-0328
1.0 HP Surface-Mount
Sump Pump Included
with System

The Importance of a Proper Pit System

Once equipment is washed, the untreated wash-water flows into your pit system. A proper pit system for your application is the first step in proper wash-water treatment, and a critical element in any wash-water recycle system.

Consult McHenry Pressure Cleaning Systems to determine the pit system configuration that works best with your application.

FIBERGLASS PITS

Part Number	Pit Size (ft.)	Description	Ship Wt.
12-0074	3x9x4.5	3-stage collection pit, fiberglass, capacity 600-gallons	480 lbs.
12-0223	3x9x4.5	3-ft. x 9-ft. baffeless pit, fiberglass, capacity 600-gallons	480 lbs.
20-9051	Fits 3x9	Above-ground external brace kit, 12-0074	250 lbs.
56-0032	Fits 3x9	Aluminum hinged diamond plate cover with 3 sections frame	100 lbs.
RC-0001-0003	Fits 3x9	Brace kit for installation of 3-stage collection pit	200 lbs.
12-0071	3x3x4.5	Catch basin, fiberglass, capacity 100-gallons	190 lbs.
20-0480A01	Fits 3x3	Steel grating for pit (2 sections)	250 lbs.
20-0733A01	Fits 3x3	Above ground external brace kit	250 lbs.
56-0031	Fits 3x3	Aluminum diamond plate cover with aluminum frame	30 lbs.
RC-0001-0002	Fits 3x3	Brace kit for installation of 3-ft. x 3-ft. pit	150 lbs.
12-0073	2x2x3	Sump pit, fiberglass, capacity 50-gallons	92 lbs.
20-0479A01	Fits 2x2	Steel grating for pit	100 lbs.
56-0030	Fits 2x2	Aluminum diamond plate cover with aluminum frame	60 lbs.
RC-0001-0001	Fits 2x2	Brace kit for installation of 2-ft. x 2-ft. pit	75 lbs.

Additional product information available in the Fiberglass Pit System Brochure.



Pressure Washers for every application

We offer over 130 models of cold and hot water pressure washers, from hand carry and portable to stationary, direct drive and belt drive, electric, gasoline, diesel and natural gas.



*HHS Series
Hot Water Electric Powered
Oil-Heater Belt Drive*



*HEG Series
Hot Water Natural Gas/LP
Belt Drive*



*HVS Series
Hot Water Gasoline
Belt Drive*



*CW Premium Series
Cold Water Electric
Belt Drive*



*JP Series
Cold Water Gasoline
Direct Drive*



Distributed by:

A large, empty rectangular box with a black border, intended for the distributor's name.